

Australia FranklinWH SLD

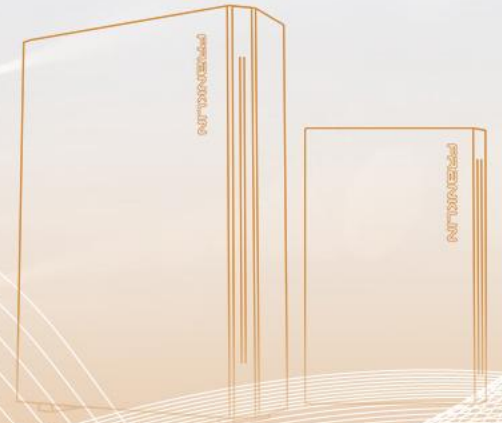

FWH aGate Power Distribution Schematic

NOTICE:

1. The switch brand is recommended as a reference. The switch needs to meet AS/NZS 60898 and local regulatory requirements.
2. There are two photovoltaic inputs, and the total power cannot exceed 15KW.
3. The smart load has two outputs, but the total power cannot exceed 15KW.

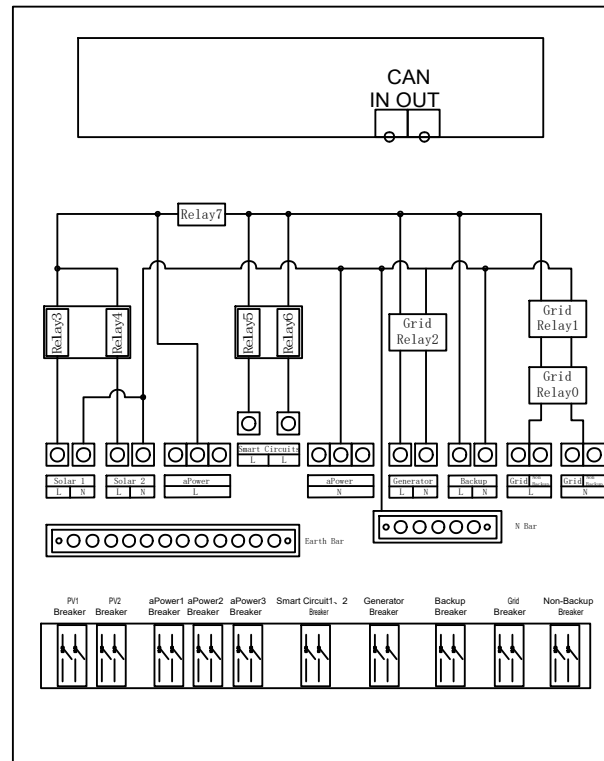

FWH Recommended Breakers, Cables List

FWH ESS Breaker	FWH ESS Breaker	MCB Max Rated Current	Rated Short-Circuit Capacity	Recommended Brands	Maximum Quantity	FWH ESS Cable	Location	Applicable Cable	Wiring Torque	Stripping Length	Cable Type
							Grid	25mm ²	5.6 Nm	12 mm	CU
	Grid	100A	10KA	ABB/Schneider/Clipsal/Hager	1		Grid	25mm ²	5.6 Nm	12 mm	CU
	Generator	100A	6KA/10KA	ABB/Schneider/Clipsal/Hager	1		Generator	25mm ²	5.6 Nm	12 mm	CU
	Back up load	100A	6KA/10KA	ABB/Schneider/Clipsal/Hager	1		Back up	25mm ²	5.6 Nm	12 mm	CU
	Non-back up load	80A	6KA/10KA	ABB/Schneider/Clipsal/Hager	1		Non-back up	16mm ²	5.0 Nm	12 mm	CU
	aPower	32A	6KA/10KA	ABB/Schneider/Clipsal/Hager	4(for aPower units > 4, please contact us)		aPower	6mm ²	3.9 Nm	12 mm	CU
	Solar	63A	6KA/10KA	ABB/Schneider/Clipsal/Hager	2		Solar	6-16mm ²	3.9-5.0 Nm	12 mm	CU
	Smart Circuits	63A	6KA/10KA	ABB/Schneider/Clipsal/Hager	2		Smart Circuits	2.5-10mm ²	3.9-4.5 Nm	12 mm	CU

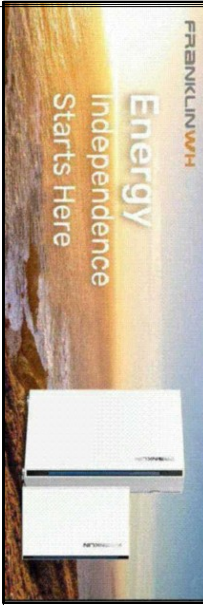

FRANKLINWVH

Email Us : service-au@franklinwh.com
 Media : media@franklinwh.com
 Business : info-au@franklinwh.com

Call Us : 1800 161 300

Address :
 Suite 4, Level 4, 4 Drake Ave,
 Macquarie Park NSW 2113

FWH ESS Single Phase SLD

NOTICE:

1. The switch brand is recommended as a reference. The switch needs to meet AS/NZS 60898 and local regulatory requirements.
2. There are two photovoltaic inputs, and the total power cannot exceed 15KW.
3. The smart load has two outputs, but the total power cannot exceed 15KW.

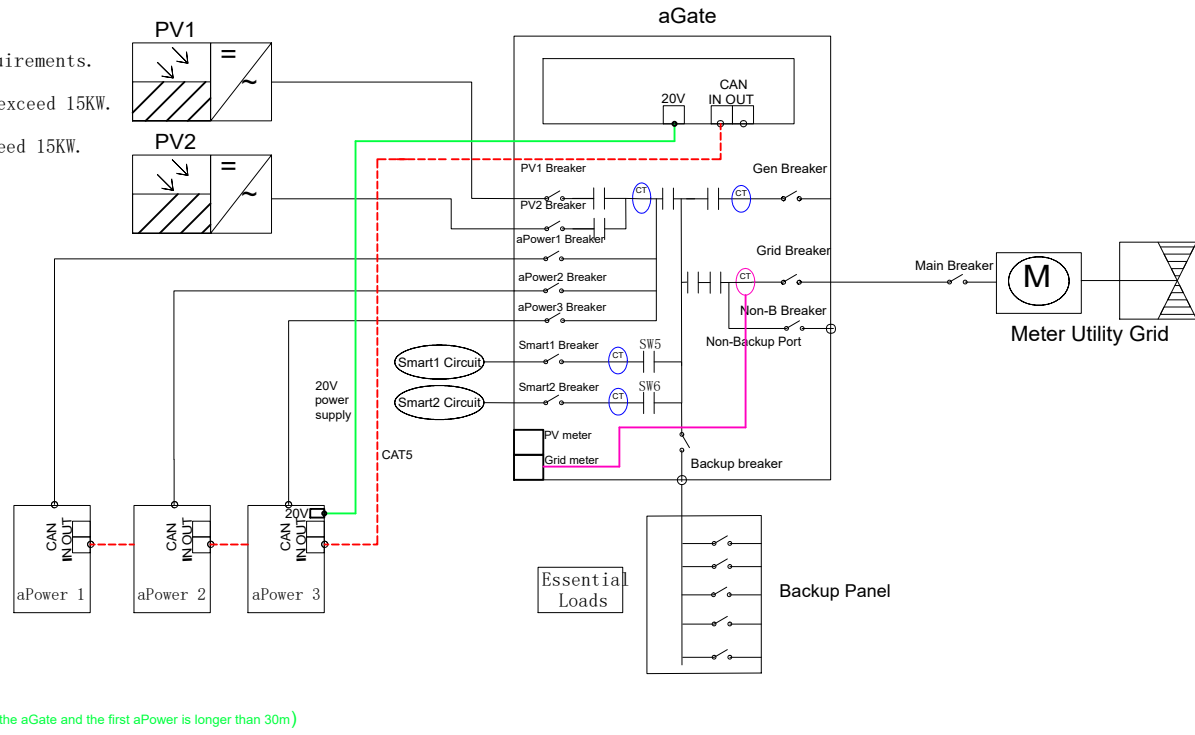

Legend:

Power Cable

Signal Cable

CT Cable

Power Cable (A 20V power supply cable must be used in conjunction when the distance between the aGate and the first aPower is longer than 30m.)

FWH Recommended Breakers, Cables List

FWH ESS Breaker	MCB Max Rated Current	Rated Short-Circuit Capacity	Recommended Brands	Maximum Quantity	FWH ESS Cable	Location	Applicable Cable	Wiring Torque	Stripping Length	Cable Type
						Grid	Generator	Back up	Non-back up	aPower
Grid	100A	10KA	ABB/Schneider/Clipsal/Hager	1		Grid	25mm ²	5.6 Nm	12 mm	CU
Generator	100A	6KA/10KA	ABB/Schneider/Clipsal/Hager	1		Generator	25mm ²	5.6 Nm	12 mm	CU
Back up load	100A	6KA/10KA	ABB/Schneider/Clipsal/Hager	1		Back up	25mm ²	5.6 Nm	12 mm	CU
Non-back up load	80A	6KA/10KA	ABB/Schneider/Clipsal/Hager	1		Non-back up	16mm ²	5.0 Nm	12 mm	CU
aPower	32A	6KA/10KA	ABB/Schneider/Clipsal/Hager	4(for aPower units > 4, please contact us)		aPower	6mm ²	3.9 Nm	12 mm	CU
Solar	63A	6KA/10KA	ABB/Schneider/Clipsal/Hager	2		Solar	6-16mm ²	3.9-5.0 Nm	12 mm	CU
Smart Circuits	63A	6KA/10KA	ABB/Schneider/Clipsal/Hager	2		Smart Circuits	2.5-10mm ²	3.9-4.5 Nm	12 mm	CU

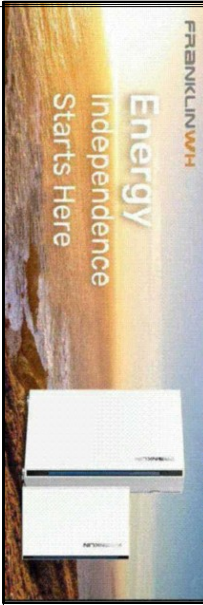

FRANKLINWH
 Email Us : service-au@franklinwh.com
 Media : media@franklinwh.com
 Business : info-au@franklinwh.com

Call Us : 1800 161 300
 Address : Suite 4, Level 4, 4 Drake Ave, Macquarie Park NSW 2113

NOTICE:

1. The switch brand is recommended as a reference. The switch needs to meet AS/NZS 60898 and local regulatory requirements.
2. There are two photovoltaic inputs, and the total power cannot exceed 15KW.
3. The smart load has two outputs, but the total power cannot exceed 15KW.

FWH ESS Three-phase Grid + Three-phase Solar SLD

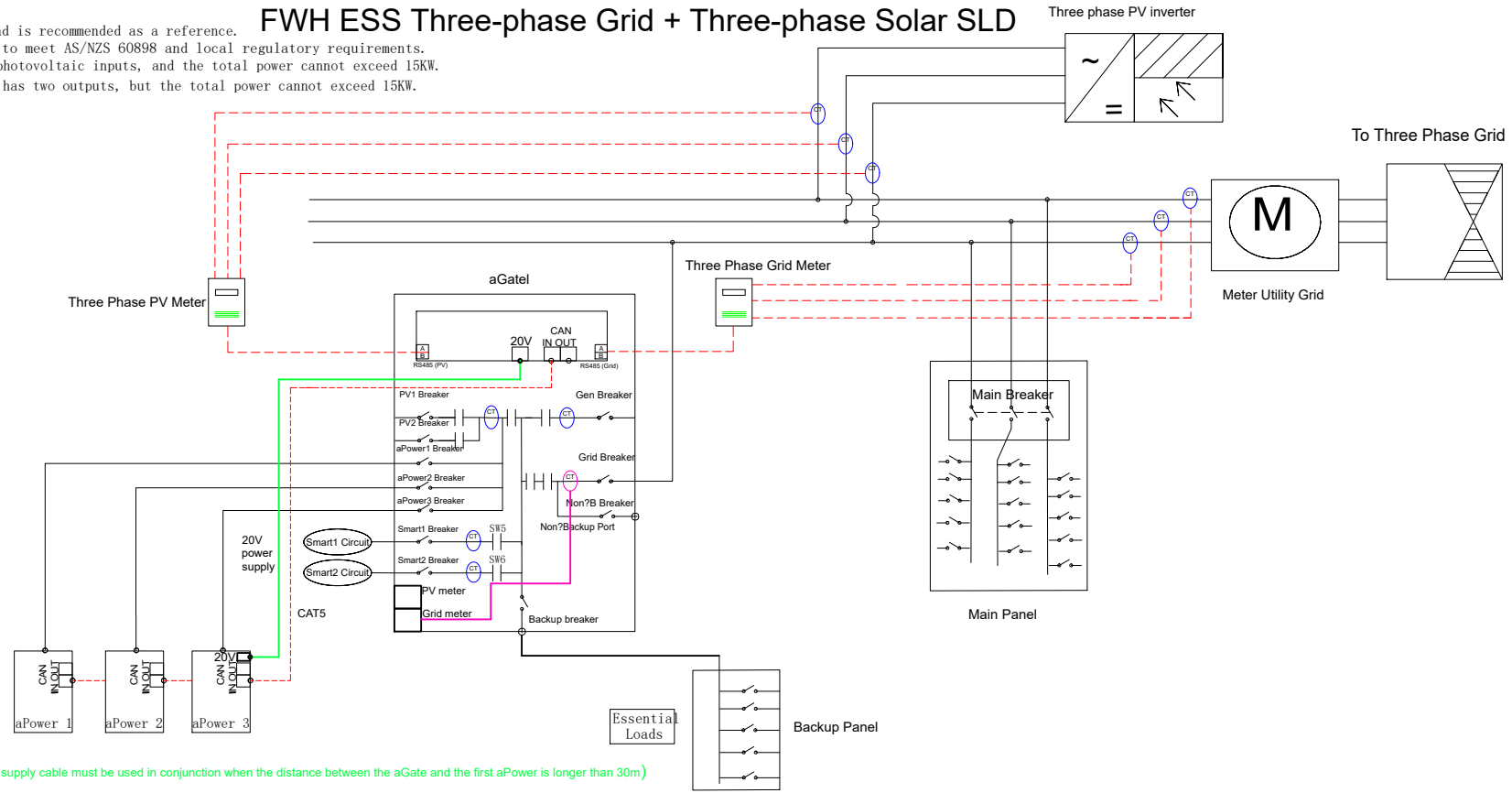

Legend:

- Power Cable
- Signal Cable
- CT Cable
- Power Cable (A 20V power supply cable must be used in conjunction when the distance between the aGate and the first aPower is longer than 30m.)

FWH Recommended Breakers, Cables List

FWH ESS Breaker	FWH ESS Breaker	MCB Max Rated Current	Rated Short-Circuit Capacity	Recommended Brands	Maximum Quantity	FWH ESS Cable	Location	Applicable Cable	Wiring Torque	Stripping Length	Cable Type
							Grid	Generator	Back up	Non-back up	aPower
	Grid	100A	10KA	ABB/Schneider/Clipsal/Hager	1		Grid	25mm ²	5.6 Nm	12 mm	CU
	Generator	100A	6KA/10KA	ABB/Schneider/Clipsal/Hager	1		Generator	25mm ²	5.6 Nm	12 mm	CU
	Back up load	100A	6KA/10KA	ABB/Schneider/Clipsal/Hager	1		Back up	25mm ²	5.6 Nm	12 mm	CU
	Non-back up load	80A	6KA/10KA	ABB/Schneider/Clipsal/Hager	1		Non-back up	16mm ²	5.0 Nm	12 mm	CU
	aPower	32A	6KA/10KA	ABB/Schneider/Clipsal/Hager	4(for aPower units > 4, please contact us)		aPower	6mm ²	3.9 Nm	12 mm	CU
	Solar	63A	6KA/10KA	ABB/Schneider/Clipsal/Hager	2		Solar	6-16mm ²	3.9-5.0 Nm	12 mm	CU
	Smart Circuits	63A	6KA/10KA	ABB/Schneider/Clipsal/Hager	2		Smart Circuits	2.5-10mm ²	3.9-4.5 Nm	12 mm	CU

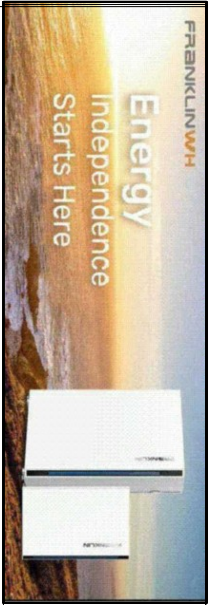

FRANKLINWH

Email Us :
 service-au@franklinwh.com
 media : media@franklinwh.com
 Business : info-au@franklinwh.com

Call Us : 1800 161 300

Address :
 Suite 4, Level 4, 4 Drake Ave,
 Macquarie Park NSW 2113

NOTICE:

1. The switch brand is recommended as a reference. The switch needs to meet AS/NZS 60898 and local regulatory requirements.
2. There are two photovoltaic inputs, and the total power cannot exceed 15KW.
3. The smart load has two outputs, but the total power cannot exceed 15KW.

FWH ESS Three-phase Grid + Three-phase Solar + one-phase Solar SLD

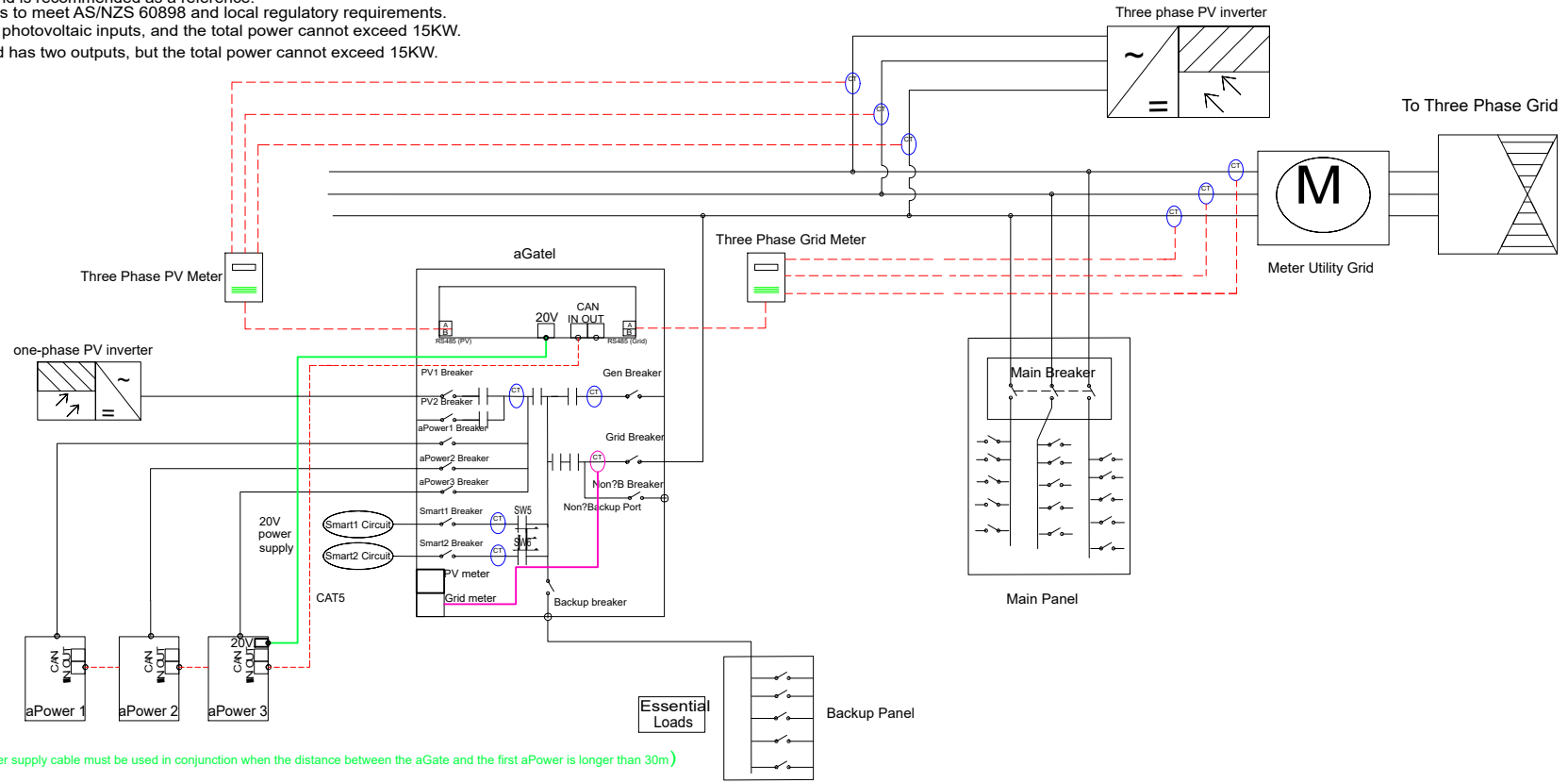

Legend

- Power Cable
- Signal Cable
- CT Cable
- Power Cable (A 20V power supply cable must be used in conjunction when the distance between the aGate and the first aPower is longer than 30m.)

FWH Recommended Breakers, Cables List

FWH ESS Breaker	FWH ESS Breaker	MCB Max Rated Current	Rated Short-Circuit Capacity	Recommended Brands	Maximum Quantity	FWH ESS Cable	Location	Applicable Cable	Wiring Torque	Stripping Length	Cable Type
							Grid	25mm ²	5.6 Nm	12 mm	CU
	Generator	100A	6KA/10KA	ABB/Schneider/Clipsal/Hager	1	Generator	25mm ²	5.6 Nm	12 mm	CU	
	Back up load	100A	6KA/10KA	ABB/Schneider/Clipsal/Hager	1	Back up	25mm ²	5.6 Nm	12 mm	CU	
	Non-back up load	80A	6KA/10KA	ABB/Schneider/Clipsal/Hager	1	Non-back up	16mm ²	5.0 Nm	12 mm	CU	
	aPower	32A	6KA/10KA	ABB/Schneider/Clipsal/Hager	4(for aPower units > 4, please contact us)	aPower	6mm ²	3.9 Nm	12 mm	CU	
	Solar	63A	6KA/10KA	ABB/Schneider/Clipsal/Hager	2	Solar	6-16mm ²	3.9-5.0 Nm	12 mm	CU	
	Smart Circuits	63A	6KA/10KA	ABB/Schneider/Clipsal/Hager	2	Smart Circuits	2.5-10mm ²	3.9-4.5 Nm	12 mm	CU	

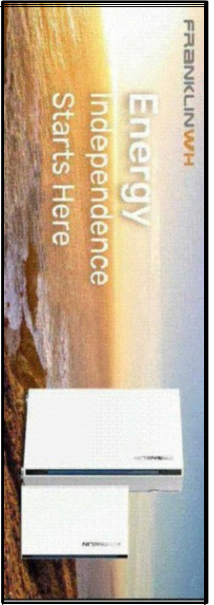

FRANKLINWVH
 Email Us : service-au@franklinwv.com
 Media : media@franklinwv.com
 Business : info-au@franklinwv.com

Call Us : 1800 161 300
 Address : Suite 4, Level 4, 4 Drake Ave, Macquarie Park NSW 2113

NOTICE:

1. The switch brand is recommended as a reference. The switch needs to meet AS/NZS 60898 and local regulatory requirements.
2. There are two photovoltaic inputs, and the total power cannot exceed 15KW.
3. The smart load has two outputs, but the total power cannot exceed 15KW.

FWH ESS Three-phase Grid + Single-phase Solar SLD

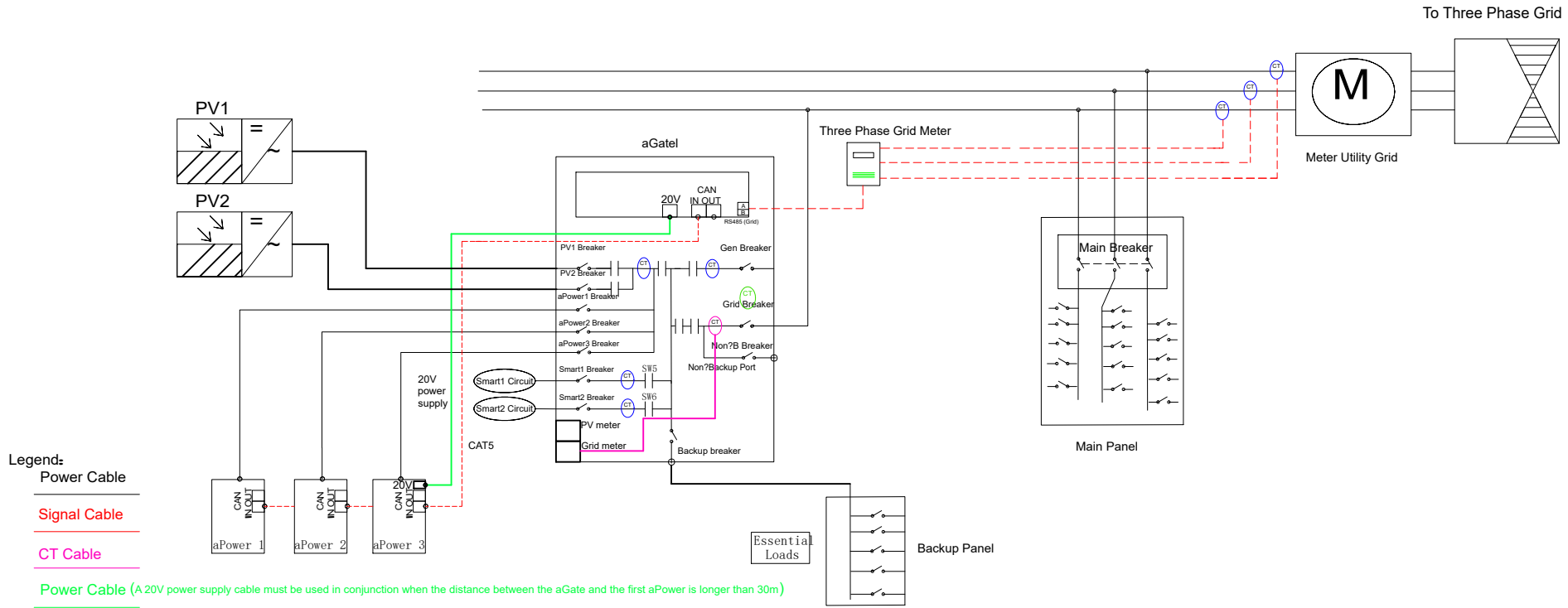

FWH Recommended Breakers, Cables List

FWH ESS Breaker	FWH ESS Breaker	MCB Max Rated Current	Rated Short-Circuit Capacity	Recommended Brands	Maximum Quantity	FWH ESS Cable	Location	Applicable Cable	Wiring Torque	Stripping Length	Cable Type
							Grid	Generator	Back up	Non-back up	aPower
	Grid	100A	10KA	ABB/Schneider/Clipsal/Hager	1		Grid	25mm ²	5.6 Nm	12 mm	CU
	Generator	100A	6KA/10KA	ABB/Schneider/Clipsal/Hager	1		Generator	25mm ²	5.6 Nm	12 mm	CU
	Back up load	100A	6KA/10KA	ABB/Schneider/Clipsal/Hager	1		Back up	25mm ²	5.6 Nm	12 mm	CU
	Non-back up load	80A	6KA/10KA	ABB/Schneider/Clipsal/Hager	1		Non-back up	16mm ²	5.0 Nm	12 mm	CU
	aPower	32A	6KA/10KA	ABB/Schneider/Clipsal/Hager	4(for aPower units > 4, please contact us)		aPower	6mm ²	3.9 Nm	12 mm	CU
	Solar	63A	6KA/10KA	ABB/Schneider/Clipsal/Hager	2		Solar	6-16mm ²	3.9-5.0 Nm	12 mm	CU
	Smart Circuits	63A	6KA/10KA	ABB/Schneider/Clipsal/Hager	2		Smart Circuits	2.5-10mm ²	3.9-4.5 Nm	12 mm	CU

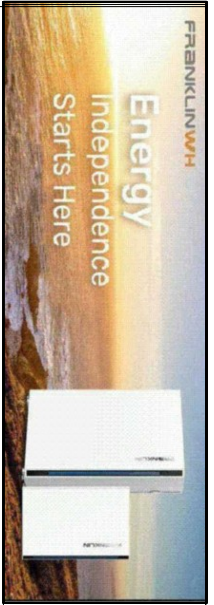

FRANKLINWH
 Email Us : service-au@franklinwh.com
 Media : media@franklinwh.com
 Business : info-au@franklinwh.com

Call Us : 1800 161 300
 Address : Suite 4, Level 4, 4 Drake Ave, Macquarie Park NSW 2113

NOTICE:

1. The switch brand is recommended as a reference. The switch needs to meet AS/NZS 60898 and local regulatory requirements.
2. There are two photovoltaic inputs, and the total power cannot exceed 15KW.
3. The smart load has two outputs, but the total power cannot exceed 15KW.

FWH ESS Three aGates and aPowers SLD

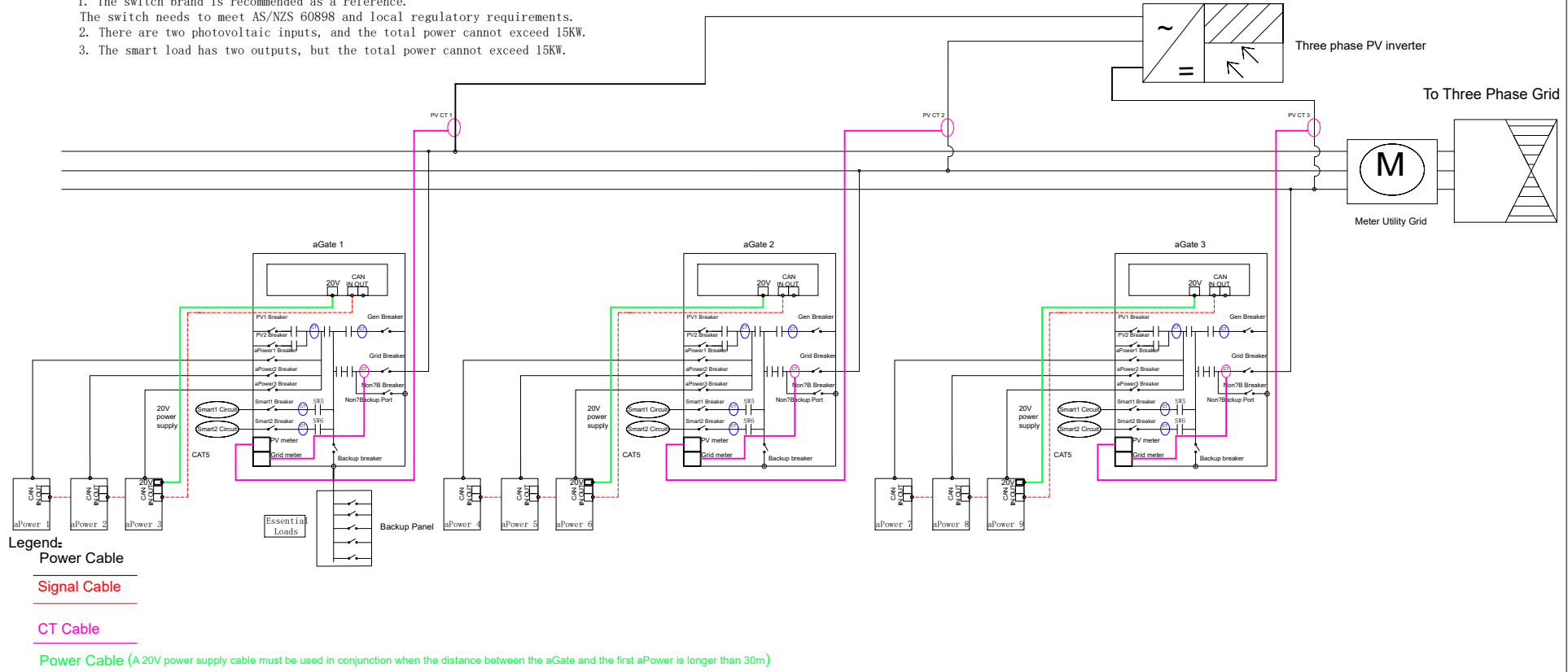

FWH Recommended Breakers, Cables List

FWH ESS Breaker	FWH ESS Breaker	MCB Max Rated Current	Rated Short-Circuit Capacity	Recommended Brands	Maximum Quantity	FWH ESS Cable	Location	Applicable Cable	Wiring Torque	Stripping Length	Cable Type
		Grid	100A	10KA	ABB/Schneider/Clipsal/Hager		1		Grid	25mm ²	5.6 Nm
	Generator	100A	6KA/10KA	ABB/Schneider/Clipsal/Hager	1		Generator	25mm ²	5.6 Nm	12 mm	CU
	Back up load	100A	6KA/10KA	ABB/Schneider/Clipsal/Hager	1		Back up	25mm ²	5.6 Nm	12 mm	CU
	Non-back up load	80A	6KA/10KA	ABB/Schneider/Clipsal/Hager	1		Non-back up	16mm ²	5.0 Nm	12 mm	CU
	aPower	32A	6KA/10KA	ABB/Schneider/Clipsal/Hager	4(for aPower units > 4, please contact us)		aPower	6mm ²	3.9 Nm	12 mm	CU
	Solar	63A	6KA/10KA	ABB/Schneider/Clipsal/Hager	2		Solar	6-16mm ²	3.9-5.0 Nm	12 mm	CU
	Smart Circuits	63A	6KA/10KA	ABB/Schneider/Clipsal/Hager	2		Smart Circuits	2.5-10mm ²	3.9-4.5 Nm	12 mm	CU

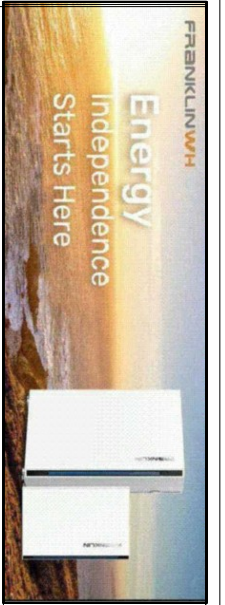

FRANKLINWVH
 Email Us : service-au@franklinwvh.com
 Media : media@franklinwvh.com
 Business : info-au@franklinwvh.com

Call Us : 1800 161 300
 Address : Suite 4, Level 4, 4 Drake Ave, Macquarie Park NSW 2113

Thanks!

www.franklinwh.com

